

CM2 COUNTING PULLEY SPECIFICATION

Issue 3, November '10

1. GENERAL

The C-MAX CM2 Counting Pulleys are designed primarily to measure the deployed length of sidescan sonar tow cable. They are available in two versions, Standard (S, shown in the photo below) and Large (L, shown overleaf). The pulleys are also available in a non-counting configuration, i.e. without the sensor unit. The large pulley is supplied with optional cable guides (not shown) that can be swung upwards to allow the cable to be fitted.

The pulleys have a circumference of 0.5m and 1.0m respectively. Rotations are counted by the sensor unit by the passing of a peripheral magnet (S), or magnets (L).

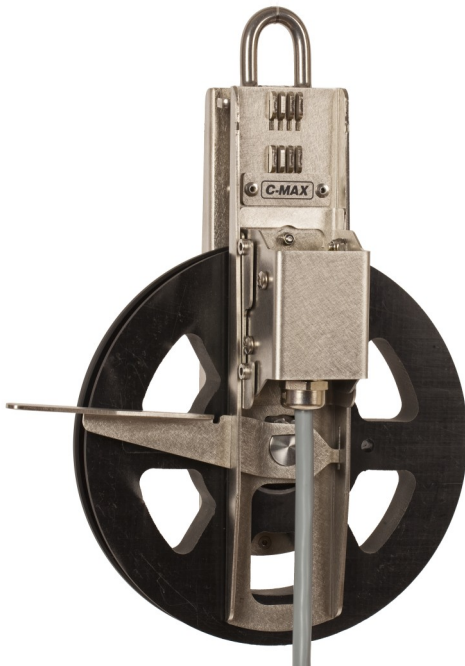

The pulley is opened to allow the cable to be fitted or removed by releasing the axle clip, then depressing the axle lever and swinging up the arm on which the axle clip is fitted.

The sensor unit is connected to the user's PC via an RS232 interface. Counting pulley display software allows the current reading to be displayed in a window.

2. INTERFACE

Interface: RS232, 4800 baud

Sensor power: extracted from the RTS and DTR lines

Interface cable length: 5m - 50m

3. DISPLAY SOFTWARE

Requires Windows 2000 or later.

Controls: Preset (to specified value), Reset

Measurement resolution: 0.5m

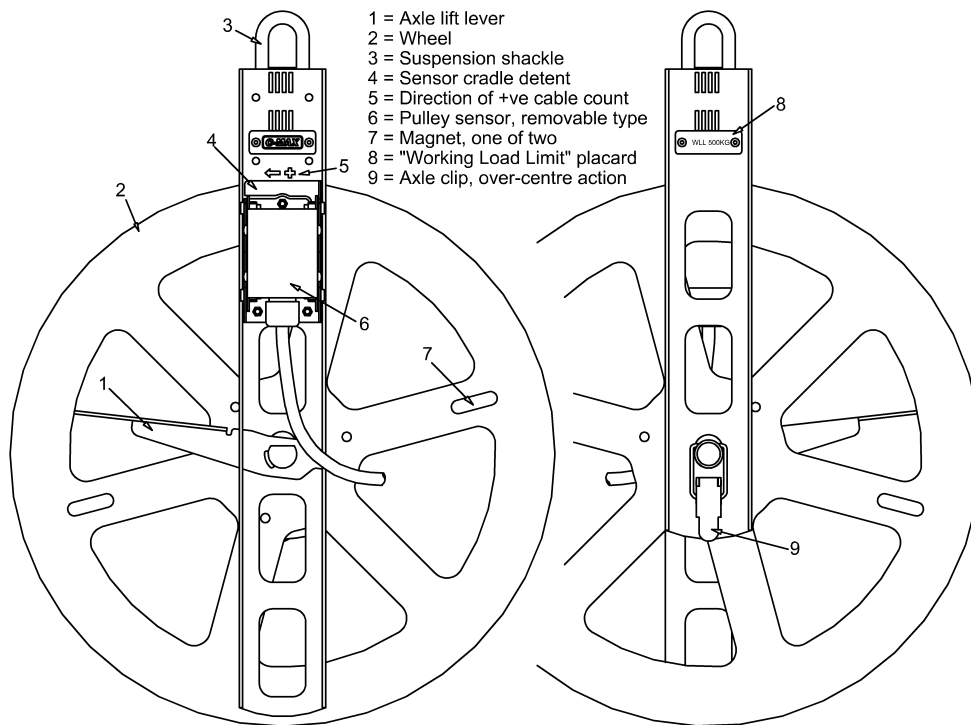

4. MECHANICAL

Working load limit: 500kg

Cable diameter: 3mm - 11mm

Cable bending radius: 79mm (S), 159mm (L)

Construction: acetal pulley, stainless steel (316) frame

Dimensions: 270 x 210 x 85mm (S), 430 x 330 x 85mm (L)

Weight: 1.5kg (S), 2.7kg (L)

The above specifications may be changed without notice.

C-MAX Ltd, 9 Hybris Business Park, Crossways, Dorchester, Dorset DT2 8BF, U.K.

Tel: +44 1305 853005, fax: +44 1305 852136, email: sales@cmasonar.com, web: cmasonar.com